

Material Characterization Tester

using the DaqBoard/2000™

Industrial

Application Note #66

Application Summary

Numerous instrument manufacturers are finding that a variety of desktop and notebook-size PCs make an economical and versatile base upon which to build their own specialized test equipment. The high speed and reliability and component standardization of modern PCs can support many types of test and data acquisition system requirements. Instrument makers can take any one of three approaches to accomplish this. Many fill the unused slots in the PC's internal bus with their own branded test and measurement boards, others use the PC only for control and data storage and connect the PC to an external piece of gear, and yet others use a combination of these two methods. The benefit to end users and operators is that they can design and build custom test modules, program custom software, use off-the-shelf software or modify it. But the final intended use of the instrument determines which one of these approaches fits best.

Potential Solution

The Quad Group, Spokane, Wash., for example, designs and manufactures a family of material characterization test instruments based upon a desktop PC, a kind of computerized workstation called the ROMULUS. The PC acts as a bed for modules or platforms that perform a variety of tests. The workstation accepts optional interchangeable platforms that measure forces from a few grams to hundreds of kilograms and lets users configure over 50 different tests with only five interchangeable platforms. The system can also measure hardness with an indenter machine. Other platforms also conduct adhesion tests, stud-pull tests, and flexure, tensile, diamond scratch, and die-shear tests. Once any instrument is purchased, other platforms, modules, and fixtures may be added individually as users' testing needs change.

For almost a decade, Quad Group used plug-in, data-acquisition boards from a well-known ISA-bus board manufacturer. But as their test requirements gradually became more demanding, especially for their semiconductor-manufacturing customers, they had to investigate replacing the 12-bit cards with more advanced 16-bit cards. However, upgrading to 16 bits with the current manufacturer proved to be relatively expensive, and not all the features they needed were readily available on one card.

IOtech's Solution

Gene Smith, electronics engineer for Quad Group, had the task of selecting a new supplier for the plug-in boards for their workstations. He evaluated the IOtech DaqBoard/2000™ and found it to be the only one of many that had all the features that he needed in one board. This included digital to analog conversion, and digital I/O. Smith uses one to two DaqBoards in each test platform and now has as many as 75 test systems in the field. "We use about 8 channels of analog input, both D/A outputs, and the counter/timer for driving and positioning a stepper motor," says Smith. "The digital I/O controls end-stop switches, and on/off functions for motors, while the D/A channels run a servomotor and heaters for temperature controls."

Smith uses strain gages with outputs in the range of 0 to 10V that correspond to as much as 0 to 550 lb., or as little as 0 to 200 g. Other platforms support temperature inputs, linear distance inputs, and piezo-acoustic wave signal inputs. Smith provides the signal conditioners for all inputs on the platform unique to each test variable and outputs a uniform, standard, 0 to 10V signal to match all DaqBoard inputs.

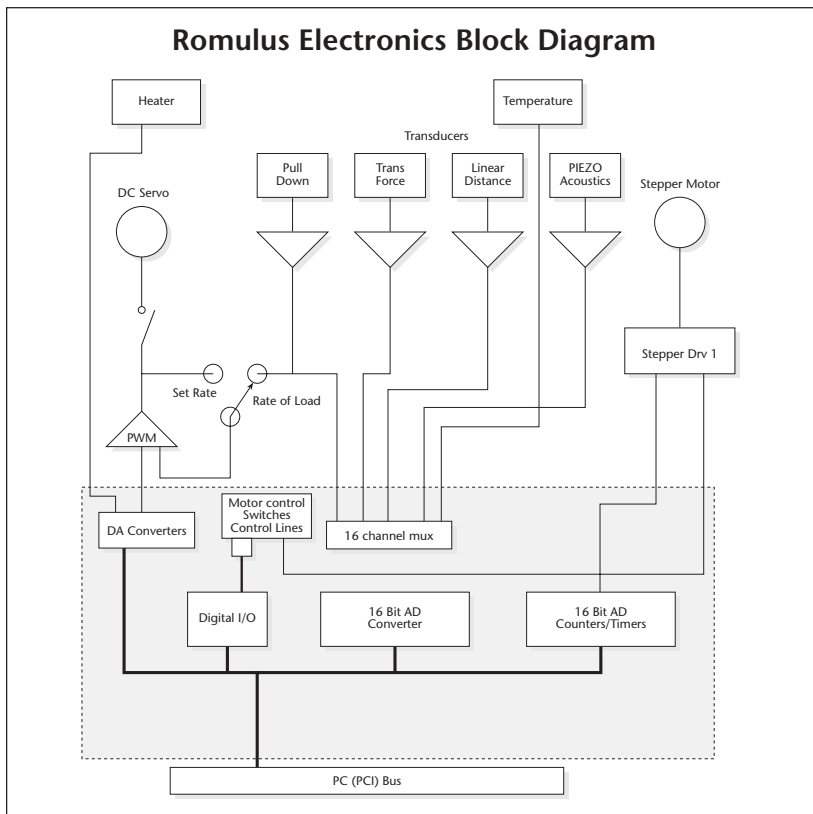

The ROMULUS material tester uses LabVIEW software and an IOtech DaqBoard/2000 as the heart of the data acquisition function as well as several control functions. The DaqBoard output controls a dc servomotor and heaters, motor control switches, and a stepper motor. Inputs include a number of transducers including temperature, linear distance, and force.



www.iotech.com

Some of the machines Quad Group designs and builds are customized, but many are off-the-shelf. "In either case," says Smith, "the DaqBoards pretty much fit our needs to a T." Furthermore, Smith uses LabVIEW® software. Although he has not been programming the software himself, Smith says the feedback from both programmers and users has always been favorable. The LabVIEW software is an open architecture that lets developers customize their tasks or make field changes as product-testing requirements change over time.

One customized test instrument that Quad Group provides is for integrated circuit front-end and back-end applications and all forms of instruments for the semiconductor manufacturing industry including Multi-Chip-Module applications. They test the substrates, the silicon wafers, and the coatings placed on the substrates for adhesion strength. But the same coating adherence and adhesion testers for microelectronics products work equally well for various industrial markets and R&D settings

Quad Group also builds an off-the-shelf, blade cutting adhesion tester called a Hesiometer. It uses a sharp blade that cuts the coating from the surface. Applications include testing paints, that is, how well the paint sticks to a primer, and how well the primer sticks to the metal. The Hesiometer can basically cut the layers between the interfaces. The military uses the Hesiometers for testing anti-fouling paints for ships.

Conclusion

Quad Group designs and builds materials test instruments using a computer workstation that accommodates up to five different platforms for materials testing and characterization. The workstation comprises a PC with several DaqBoard/2000 data acquisition boards, and the optional platforms allow users to configure up to 50 different tests, including hardness, adhesion, yield strength, work hardening, and stud pull tests for industrial and microelectronic wafer interconnect technology. The system is highly flexible, economical, and reliable. Modularity of the units provides customers with a compact instrument, which is only 1.2-ft. square.

DaqBoard/2000 Series

The new DaqBoard/2000™ series sets the price/performance benchmark for high-speed, multi-function plug-and-play data acquisition for PCI bus computers. The DaqBoard/2000 series hardware design offers all of the features normally found on significantly more expensive boards, including 16-bit, 200-kHz A/D, 100% digital calibration, bus mastering, two or four 16-bit, 100-kHz D/A converters, 40 digital I/O lines, four counters and two timers. The DaqBoard/2000 series is supported by a growing family of over 30 signal conditioning and expansion options, offering signal conditioning for thermocouples, RTDs, accelerometers, isolation, high-voltage, strain gages, and much more.

Features

- Six PCI (DaqBoard/2000) and six CompactPCI® (DaqBoard/2000c) versions available
- 16-bit, 200-kHz A/D converter
- 8 differential or 16 single-ended analog inputs (software selectable per channel)
- Expandable up to 256 analog input channels, while maintaining 200 kHz (5 µs per channel) scan rate
- Up to four boards can be installed into one PC for up to 1024 analog input channels
- 100% digital calibration
- 512 location channel/gain FIFO, capable of scanning all channels, including 256 analog expansion channels and digital/counter channels, at 5 µs per channel
- DMA bus mastering for synchronous analog I/O, digital I/O, and counter inputs
- Trigger modes include analog, digital, & software, with <5 µs latency
- Virtually infinite pre-trigger buffer*
- Up to four 16-bit, 100-kHz analog outputs with infinite continuous waveform output capability*
- 40 digital I/O lines, can be scanned synchronously or asynchronously with analog inputs
- Digital I/O is expandable up to 272 lines, including optional isolation and relay closure
- Four counter/pulse input channels can be scanned synchronously or asynchronously with analog inputs
- Two timer/pulse output channels

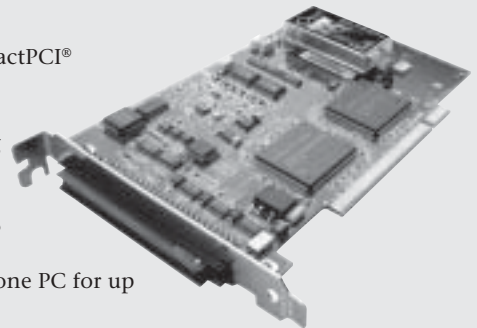

DaqView2000™ graphical data acquisition and display software is available for all DaqBoard/2000 series systems.

* Limited only by available PC RAM and hard disk space

DaqBoard/2000™, DaqCOM™, DaqView™, and Out-of-the-Box™ are the property of IOtech; all other trademarks and tradenames are the property of their respective holders. 030407.

Software

- Included DaqX API library, drivers for Visual Basic®, C++, and Delphi™ for Windows® 95 and higher; C++ for Linux, DASyLab®, TestPoint®, and LabVIEW®
- Optional DaqView2000™ software package
- Optional DaqCOM™ ActiveX/COM-based applications program interface, including network capability